

Seevision Technologies Inc.

Making America Greener One Light At A Time

LED STREET & PARKING LIGHT PRODUCTS

56 WATT INTEGRATED LED LAMP HEADPIECE



SVT-SLLU2-56W

APPLICATIONS

Integrated lamp & fixture designed for the direct replacement of fixtures containing metal halide, sodium or mercury lamps up to 250 Watts.

All-Inclusive LED Cobrahead Replacement Solution

Street / Sidewalk / Pathway / Parking Lot & Garage Lighting

Park Grounds / Airport / Marina / School & Gas Station Lighting

Residential & Commercial Building Exterior Security & Common Area Lighting

NEW YORK
516 - 754 - 8328

EMAIL US
sales@seevisiontechnologies.com

FLORIDA
352 - 597 - 9025

FEATURES & BENEFITS

Lighting Energy Cost Savings	Energy consumption up to 80% less than standard metal halide, sodium & mercury lamps.
	Requires no ballast; significantly reducing total energy consumption used per fixture.
Replacement Lamp & Labor Cost Savings	Life duration is over 50,000 Hours; 5-10X longer than standard metal halide, HPS & mercury lamps.
Replacement Ballast & Labor Cost Savings	Requires no ballast; completely eliminating all replacement ballast & labor costs.
Universal & Adjustable Lamp Pole Installation	Adjustable hoop provides quick and easy installation on any lamp pole.
Unique Modular Slide-Shell Design	Combination lamp & shell module provides simple and convenient access for maintenance.
Low Profile Fixture Design	Slim appearance reduces overall weight and wind force load on lamp pole.
Durable & Safe Lamp Design	Impact resistant & shock-proof design; no fragile glass for improved safety & durability.
Integrated Radiator & Lampholder Design	Protects LED life duration by dissipating heat away from the light source components.
Integrated Lens & Lamphshade Design	Array lens play a protective and spot light role; avoiding wasteful duplication and loss of light.
Revolutionary Dedicated Optical System	Rectangular beam focusing lens ensures an ideal uniformity of brightness on surface area.
Eliminate Adverse Glare & Light Pollution	Controlled light distribution eliminates the glare and visual fatigue sight interference common with traditional street lights.
	Improves overall driving safety and reduces the occurrence of traffic accidents.
Low Voltage Operation	Eliminates lamphshade dust absorption and reduced brightness caused by high voltage.
Low Temperature Operation	Eliminates lamphshade discoloration and reduced life duration & brightness caused by heat.
Instant Brightness Start Up Without Delay	Reaches normal brightness as soon as power is applied; eliminating long start up delays of traditional high output flood & street light lamps.
Bright & Clean Light Emittance	High color rendering index; up to 10X the brightness per watt of standard street lamps.
Intelligent Current Control	Each LED module has the ability to monitor and adjust to achieve a precise constant current.
Universal Input Voltage	85-264V AC full voltage range constant with precision constant current PWM technology.
Compatible Integration With Solar Energy Solutions	Achieve best cost savings by combining low voltage LED lamps with solar energy solutions.

FEATURES & BENEFITS (continued)

Environmentally Safe & Recyclable	Contains no harmful gases, mercury, sodium, lead or UV radiation (100% recyclable).
Green Rebates & Incentives	Qualifies for many Federal, State, Local Government & Utility based rebates & incentives.

TECHNICAL SPECIFICATIONS

LED Power Consumption	56 Watts			
Power Supply Consumption	10 Watts			
Input Voltage	85-264V AC			
Frequency Range	47 ~ 63 Hz			
Power Factor	>0.9			
Total Harmonic Distortion	<20%			
Power Efficiency	85%			
Working Voltage	24V DC			
LED Luminous Efficiency	≥80 lm/w			
LED Initial Flux	5,000 lm (T _j =25°C)			
LED Maintain Flux	4,600 lm (T _j =60°C, T _a =25°C)			
Lamp Output Flux	4,200 lm (T _j =60°C, T _a =25°C)			
Lamp Efficiency (%)	>90%			
Illumination (E) HPS Equivalent Effective Illuminated Area	HEIGHT	LED LUX	HPS LUX	ILLUMINATED AREA
	6m	≥26	65	20m x 8m
	8m	≥15	38	26m x 10m
	10m	≥9	20	33m x 13m
	12m	≥6	15	40m x 16m
Emission Color	Pure White			5000K - 7000K
	Warm White			3000K - 4000K
Color Rendering Index (CRI)	Ra>75			
Light Source	LED Emitter (1 Watt)			
Light Distribution Curve/Pattern	Asymmetric (Bat Wing)			
	Rectangular Beam			
Light Beam Angle	120°	Horizontal Axis		110° Beam
		Vertical Axis		45° Beam
	140°	Horizontal Axis		130° Beam
		Vertical Axis		45° Beam
Highest Light Intensity Angle	120°	Horizontal Axis		110° Beam
		Vertical Axis		45° Beam
	140°	Horizontal Axis		130° Beam
		Vertical Axis		45° Beam
Junction Temperature (T _j)	60° C ± 10% (T _a = 25° C)			
System Resistance (R _{ja})	0.56° C / W			

TECHNICAL SPECIFICATIONS (continued)

Working Temperature	- 30° C ~ 50° C
Working Humidity	10% ~ 90% RH
Storage Temperature	10° C ~ 85° C
Life Duration	50,000 Hours
Base Type	Universal adjustable hoop lamp pole mount
Materials: Body & Lampshade	Aluminum Alloy / PC
IP Rating	IP 65
Net Weight	7 kgs (15.44 lbs)
Dimensions (L x W x H)	540mm x 315mm x 90mm
	24.8" x 12.6" x 3.6"
Certifications	CE, RoHS, UL
Available Options	320V AC Voltage Supply w/ Sensor
	Easy Access Terminal Block Door

DIMENSIONS

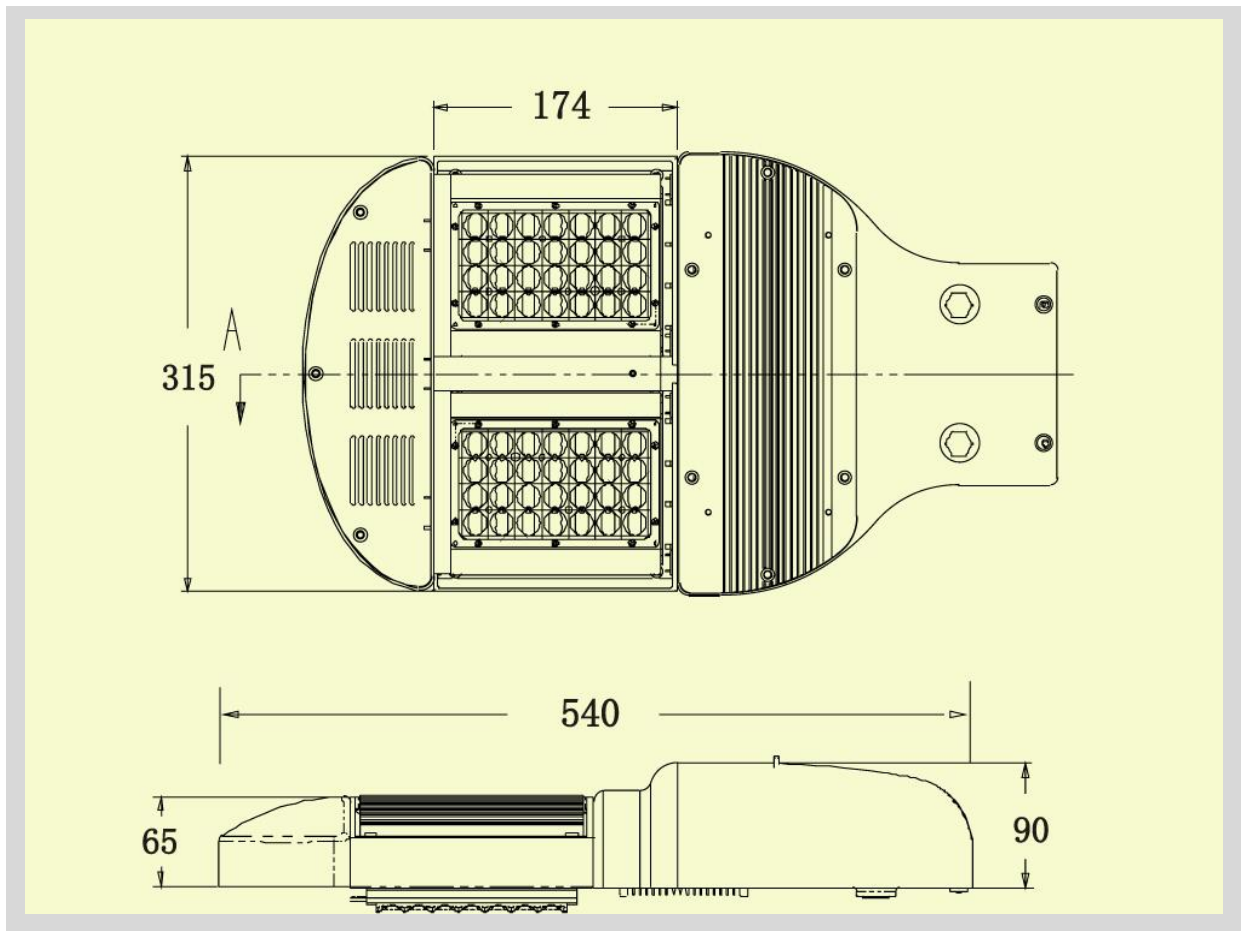

NEW YORK 516 - 754 - 8328	EMAIL US sales@seevisiontechnologies.com	FLORIDA 352 - 597 - 9025
-------------------------------------	---	------------------------------------